

TUV Ø 26 mm T8

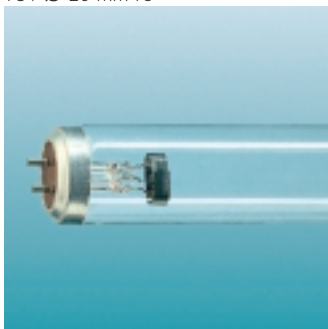

TUV Ø 38 mm T12

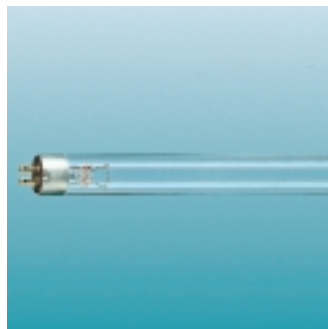

TUV Miniature T5



TUV PL-S



TUV PL-L

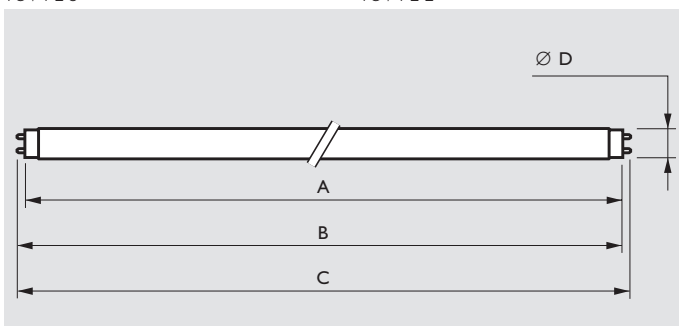

Dimensions in mm

TUV disinfection lamps are low-pressure mercury-vapour discharge lamps consisting of a tubular glass envelope, emitting short-wave ultraviolet radiation with a radiation peak at 253.7 nm (UV-C) for germicidal action. The glass filters out the 185 nm ozone-forming line. A protective coating on the inside limits the depreciation of the useful UV-C radiation output (Longlife lamps). PL-S have a specially adapted starter providing almost instant starting characteristics already built into the lamp base.

Note

The UV-C radiation output of these lamps is indicated by the following warning sign.



Radiation of these lamps is harmful to eyes and skin. Installations with these lamps are to be screened off completely.

Applications

TUV lamps are used for killing or inactivating bacteria, viruses and other primitive organisms. Typical application examples include air; water and surface disinfection in hospitals, bacteriological research and pharmaceutical institutions, and food processing industries, such as dairies, breweries and bakeries. They are also used for the disinfection of drinking water; waste water; swimming pools; air conditioning systems; cold storage rooms; packing material, etc.

Finally, they are applied in a variety of photochemical processes.

Type	A max.	B min.	B max.	C max.	D max.
Cap/base G5					
TUV 4W	135.9	140.6	143.0	150.1	16.0
TUV 6W	212.1	216.8	219.2	226.3	16.0
TUV 8W	288.3	293.0	295.4	302.5	16.0
TUV 11W	212.1	216.8	219.2	226.3	16.0
TUV 16W	288.3	293.0	295.4	302.5	16.0
Cap/base G13					
TUV 10W	331.5	336.2	338.6	345.7	28.0
TUV 15W	437.4	442.1	444.5	451.6	28.0
TUV 25W	437.4	442.1	444.5	451.6	28.0
TUV 30W	894.6	899.3	901.7	908.8	28.0
TUV 36W	1199.4	1204.1	1206.5	1213.6	28.0
TUV 55W HO	894.6	899.3	901.7	908.8	28.0
TUV 75W HO	1199.4	1204.1	1206.5	1213.6	28.0
TUV 115W VHO, -R VHO	1199.4	1204.1	1206.5	1213.6	40.5

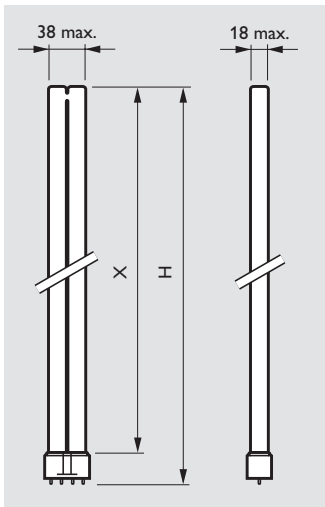

Type	X max.	H max.
Cap/base 2G11		
TUV 18W PL-L	195	225
TUV 36W PL-L	385	415
TUV 55W PL-L	505	535

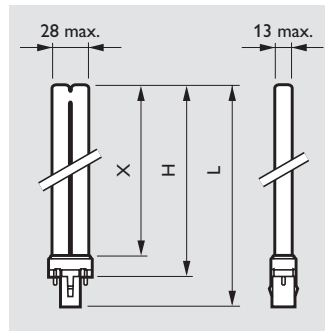

Type	X max.	H max.	L max.
Cap/base G23			
TUV 5W PL-S	67	83	105
TUV 9W PL-S	129	145	167
TUV 11W PL-S	198	214	236

Dimensions in mm

Type	Cap/base	Lamp voltage V	Lamp current A	UV-C radiation W	Useful life h	Depreciation 5000 hrs %	Nett weight g	Ordering number	EOC
TUV									
TUV 4W	G5	29	0.17	0.7	5000	30	16	9280 001 04000	638724
TUV 6W	G5	42	0.16	1.5	8000	25	22	9280 007 04000	623645
TUV 8W	G5	56	0.15	2.1	8000	20	29	9280 011 04000	623683
TUV 11W	G5	37	0.33	2.1	8000	25	22	9280 022 04000	559654
TUV 16W	G5	46	0.35	3.4	8000	20	29	9280 020 04000	638694
TUV 10W	G13	45	0.23	2.5	8000	10	62	9280 241 04000	560216
TUV 15W	G13	51	0.34	4.6	8000	12	75	9280 390 04000	726179
TUV 25W	G13	46	0.60	7.0	8000	12	75	9280 394 04000	641618
TUV 30W	G13	100	0.37	11.2	8000	12	140	9280 395 04000	726209
TUV 36W	G13	103	0.44	14.6	8000	12	186	9280 486 04000	618542
TUV 55W HO	G13	83	0.77	16.5	8000	12	140	9280 495 04000	618665
TUV 75W HO	G13	108	0.84	25.5	8000	12	140	9280 494 04000	618511
TUV 115W VHO	G13	92	1.50	37.7	5000	12	290	9280 497 04000	617590
TUV 115W -RVHO	G13	92	1.50	31.0	5000	15	293	9280 496 04000	627193
TUV PL-S									
TUV 5W PL-S	G23	34	0.18	1.0	8000	15	30	9279 005 04000	642486
TUV 9W PL-S	G23	60	0.17	2.4	8000	15	41	9279 017 04000	618245
TUV 11W PL-S	G23	89	0.16	3.6	8000	15	58	9279 023 04000	624888
TUV PL-L									
TUV 18W PL-L	2G11	60	0.37	5.5	8000	15	66	9279 030 04000	624925
TUV 36W PL-L	2G11	105	0.44	12.0	8000	15	114	9279 034 04000	628787
TUV 55W HF PL-L	2G11	103	0.54	17.0	8000	15	145	9279 087 04000	633798

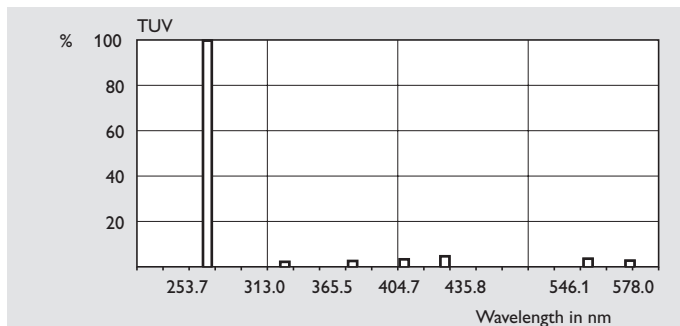

Spectral power distribution

